

- BEST. TERRAIN PARZELLENGRENZE
- BEST. TERRAIN FASSADENFLUCHT
- NEUES TERRAIN FASSADENFLUCHT

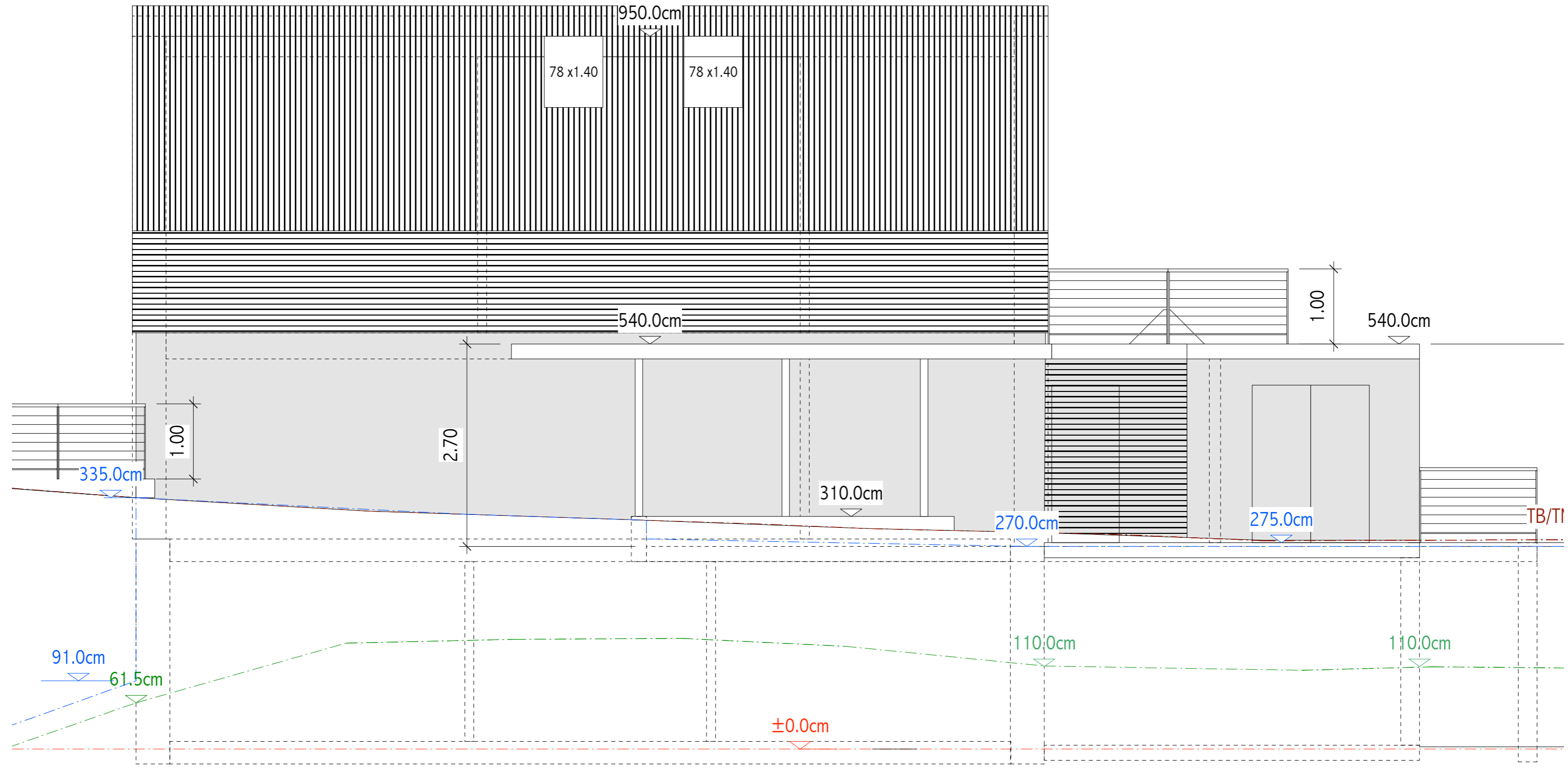

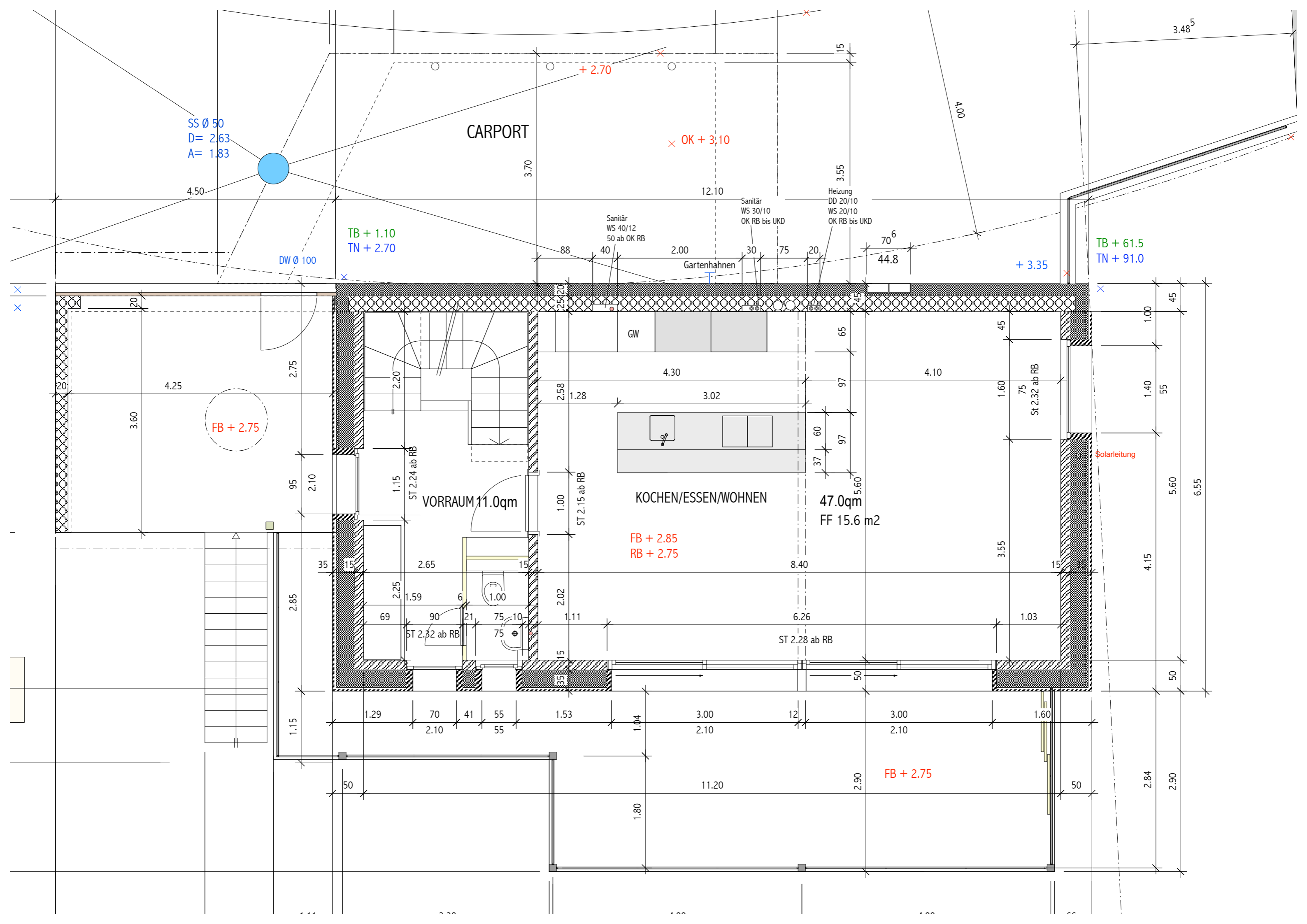

SS Ø 50
D= 2.63
A= 1.83

CARPORT

OK + 3,10

TB + 1.10
TN + 2.70

DW Ø 100

Sanitär
WS 40/12
50 ab OK RB

Sanitär
WS 30/10
OK RB bis UKD

Heizung
DD 20/10
WS 20/10
OK RB bis UKD

Gartenhähnen

TB + 61.5
TN + 91.0

+ 3.35

FB + 2.75

KOCHEN/ESSEN/WOHNEN

47.0qm
FF 15.6 m2

FB + 2.85
RB + 2.75

VORRAUM 11.0qm

Solarleitung

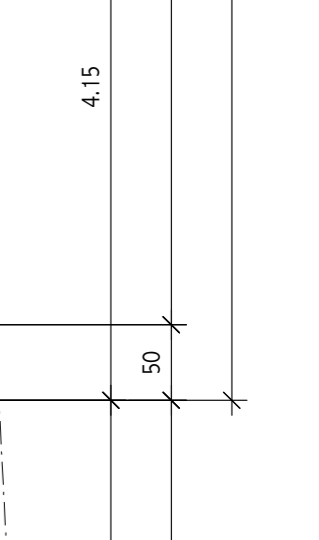
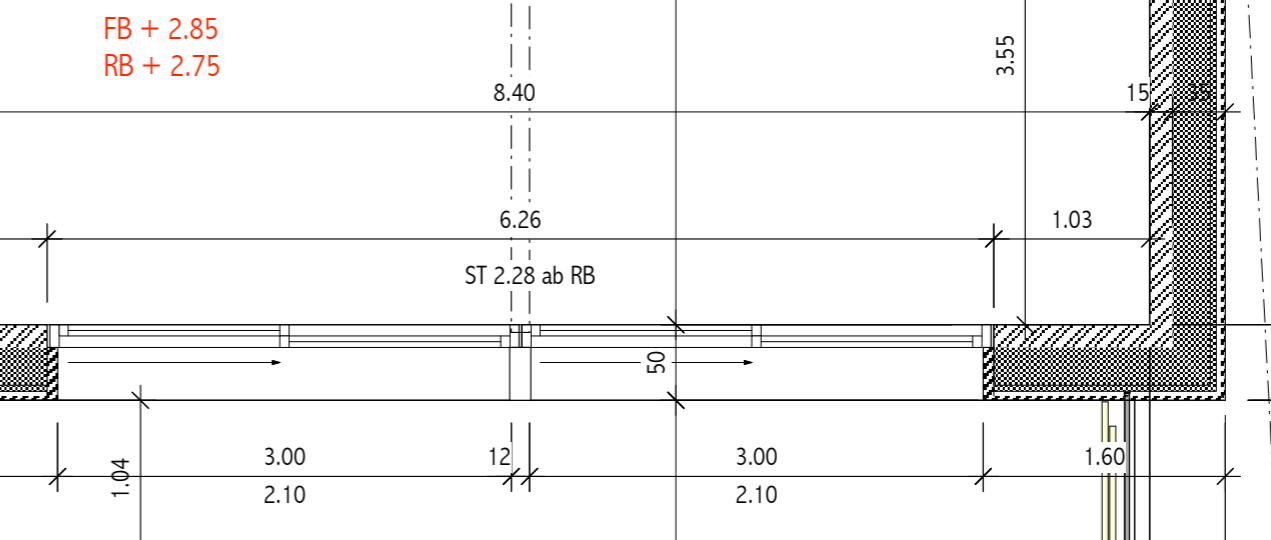
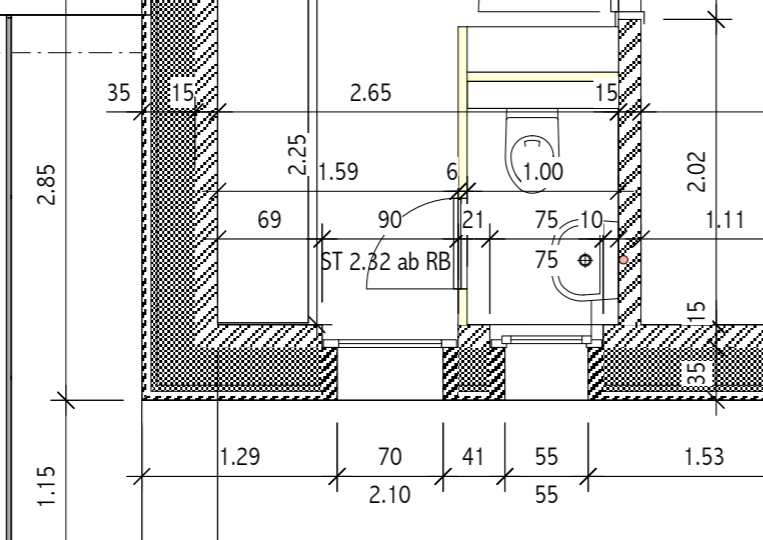
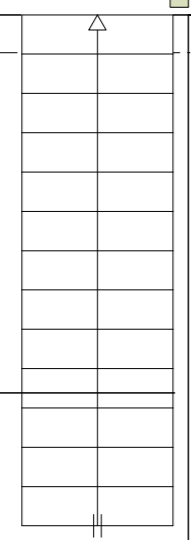

Dach:
 3-Schichtplatte 2.7 cm
 Binder/Cellulose 20/33.3 cm
 Holzfaserplatte 4 cm
 Hinterlüftung 5 cm
 Betonziegel

Aussenwand:
 Fermacell 1.5 cm
 Fuchs 9 cm
 Upsi/Cellulose 25 cm
 Holzfaserplatte 4 cm
 Hinterlüftung 2.8 cm
 Schalung 2.7 cm

Aussenwand:
 Aussenisolation 20 cm
 Beton 25 cm
 Abrieb

Boden:
 Bodenbelag 1 cm
 Unterlagsboden 6 cm
 Isolation 2 cm
 Beton 20 cm
 Misapor 30 cm

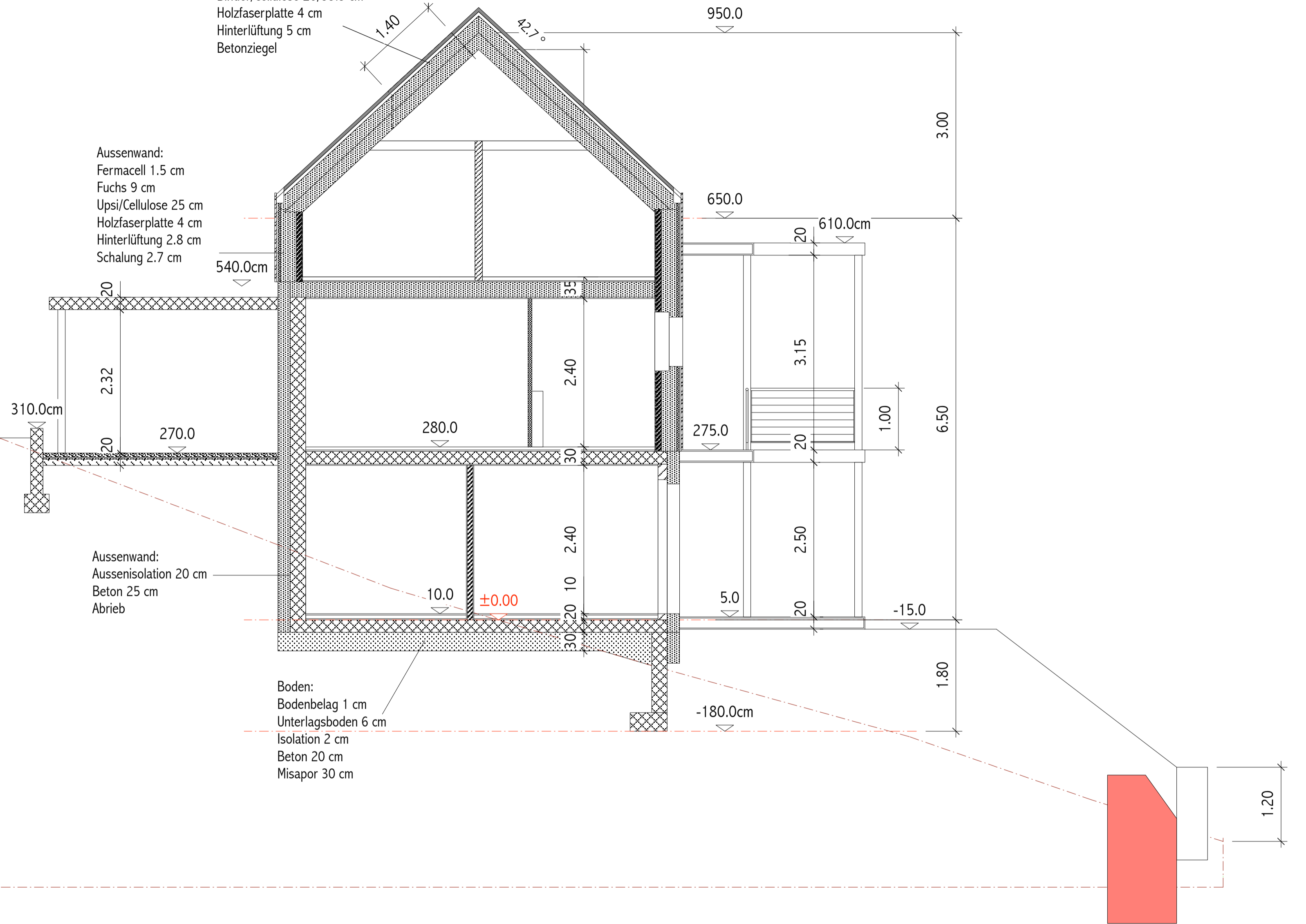

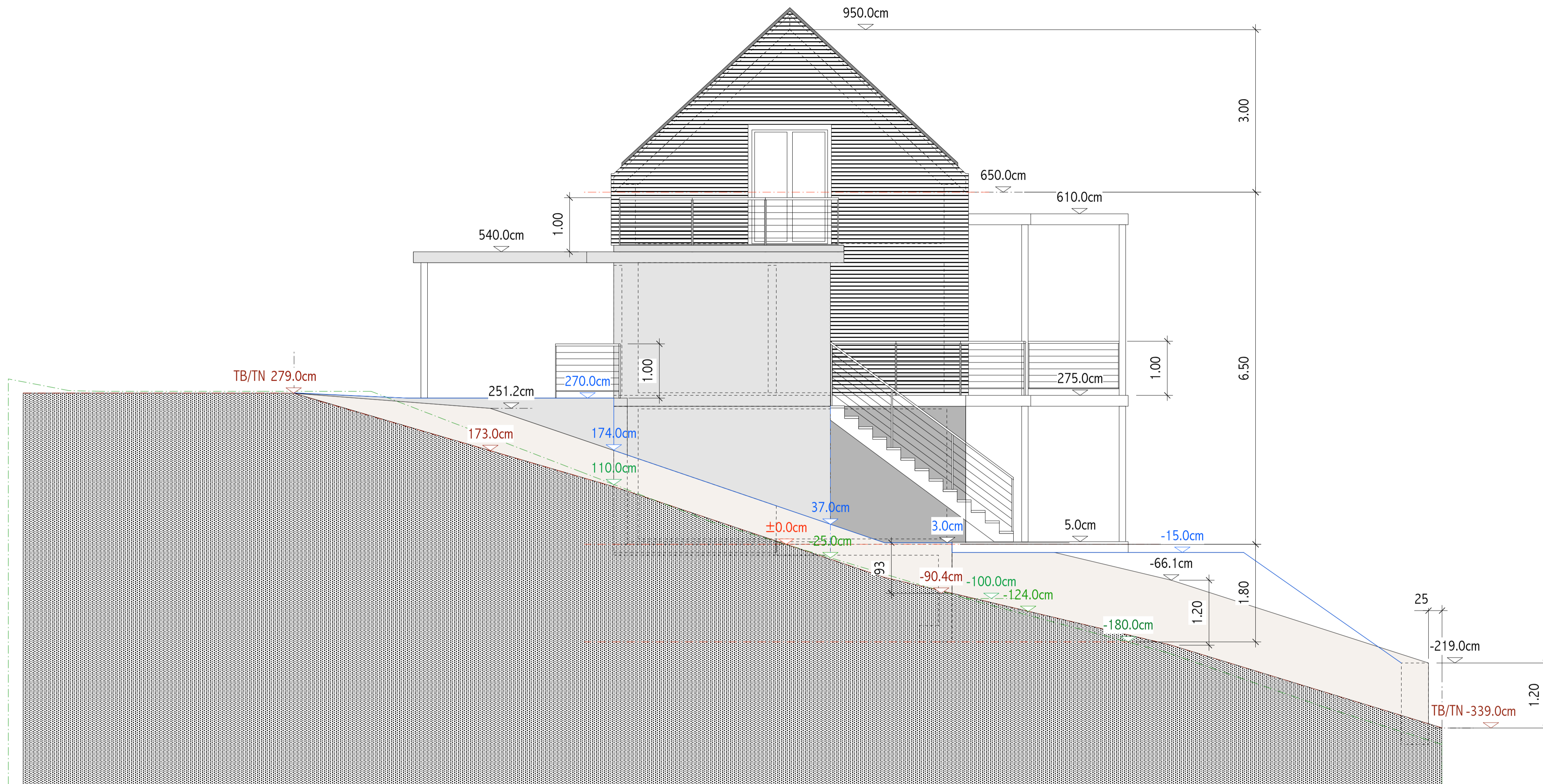

- BEST. TERRAIN PARZI
- BEST. TERRAIN FASS/
- NEUES TERRAIN FASS

ARCHITEKT :

PROJEKT SÜDWESTFACADE	NEUBAU EI MST 1:100
--------------------------	------------------------